

FLAT TOP TOWER CRANE



Specifications:

- ▶ Max jib length: 65,00 m
- ▶ Capacity at max length: 2,30 t
- ▶ Max capacity: 8,00 t

WORKS FOR YOU.™

KEY

Zeichenerklärung · Légende · Leyenda · Legenda · Legenda · Условные обозначения



Hoisting · Heben · Levage · Elevación · Sollevamento · Elevação · Подъем



Trolleying · Katzfahren · Distribution · Distribución · Traslazione carrello · Distribuição · Передвижение каретки



Slewing · Schwenken · Orientation · Orientació · Rotazione · Giro · Поворот



Travelling · Schienenfahren · Translation · Traslación · Traslazione · Móvel · Передвижение



Directive on noise level · Richtlinie für den Schall-Leistungspegel · Directive sur le niveau acoustique · Directiva sobre el nivel acustico · Direttiva sul livello acustico · Diretiva sobre nível de ruídos · Директива по уровню шума



Consult us · Auf Anfrage · Nous consulter · Consultarnos · Consultateci · Consulte-nos · Проконсультироваться с нами



Power requirements · Geforderte Stromstärke · Puissance totale nécessaire · Potencia necesaria · Potenza totale richiesta · Requisitos de energia · Требования по питанию



Power supply · Stromversorgung · Alimentation · Alimentación · Alimentazione · Fonte de alimentação · Питание



In service · In Betrieb · En service · En servicio · In servizio · Em serviço · При работе



Out of service · Außer Betrieb · Hors service · Fuera de servicio · Fuori servizio · Fora de serviço · В режиме простоя



Max. under hook height · Höchste Hakenhöhe · Hauteur maxi. sous crochet · Maxima altura bajo gancho · Altezza max. sotto gancho · Alt. máx. sob o gancho · Макс высота крюка



Without load, without ballast, max. jib and max. height · Ohne Last und Ballast, mit Maximalausleger und Maximalhöhe · A vide, sans lest, avec flèche et hauteur maximum · Sin carga, sin lastre, con pluma y altura máxima · A vuoto, senza zavorra, braccio max., altezza max. · Sem carga, sem lastro, lança máxima, altura máxima · Без груза, без балласта, на макс. Длине вспомогательной стрелы и макс. Высоте



Counterweight · Gegengewicht · Lest de contre-flèche · Lastre de contra flecha · Zavorra controbraccio · Contrapeso · Противовес

C25

EN 14439-C25

CONTENTS

СТТ 202-8

Inhalt · Contenu · Contenido · Indice · Sumário · Содержание

Page · Seite · Page · Página · Pagina · Página · Страница:

Load Diagram · Lastkurven · Courbes de charges · Curvas de cargas · Diagramma di portata · Diagrama de carga · Диаграмма грузоподъёмности.....	4
Tower · Turm · Tour · Torre · Torre · Torre · Башня	8
Mechanisms · Antriebe · Mécanismes · Mecanismos · Meccanismi · Mecanismo · Механизм	14
Transportation · Transport · Transport · Transporte · Trasporto · Transporte · Транспортировка	15

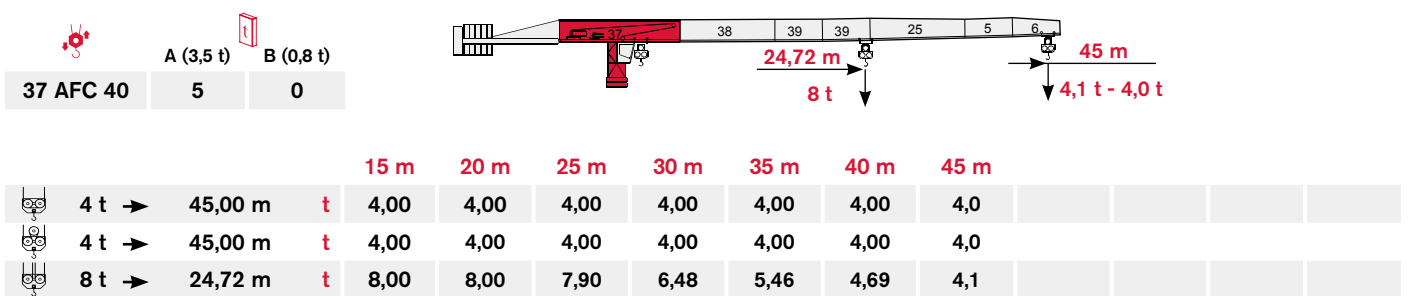
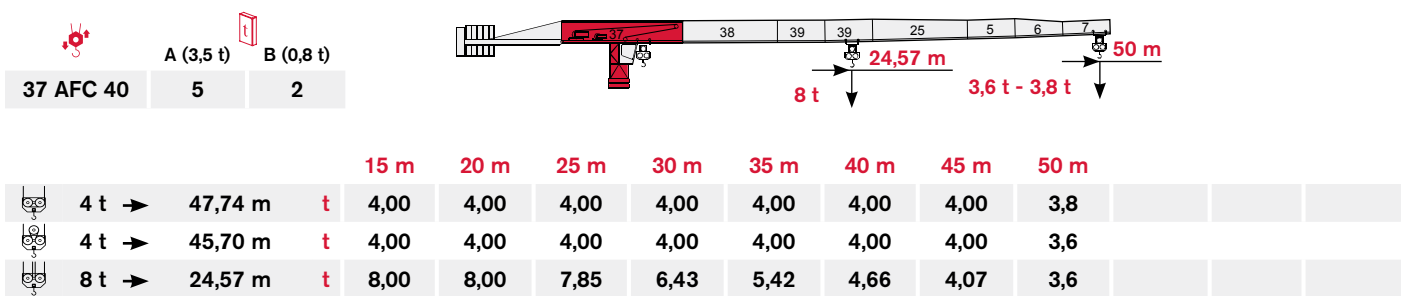
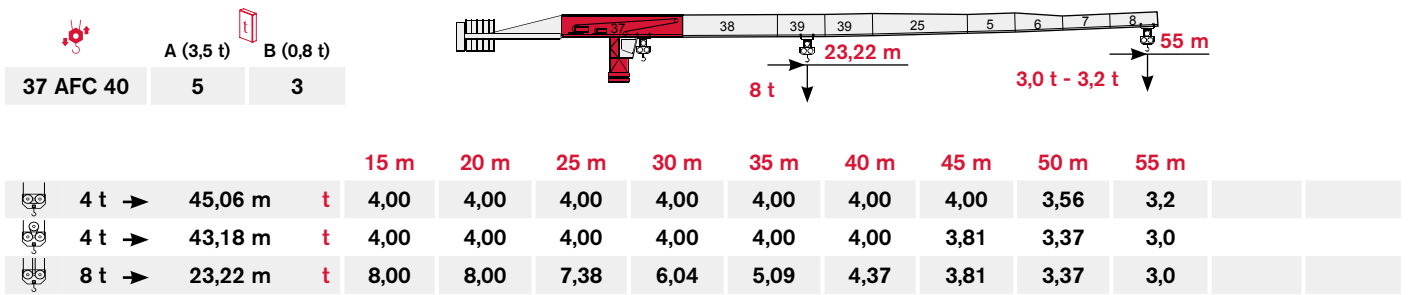
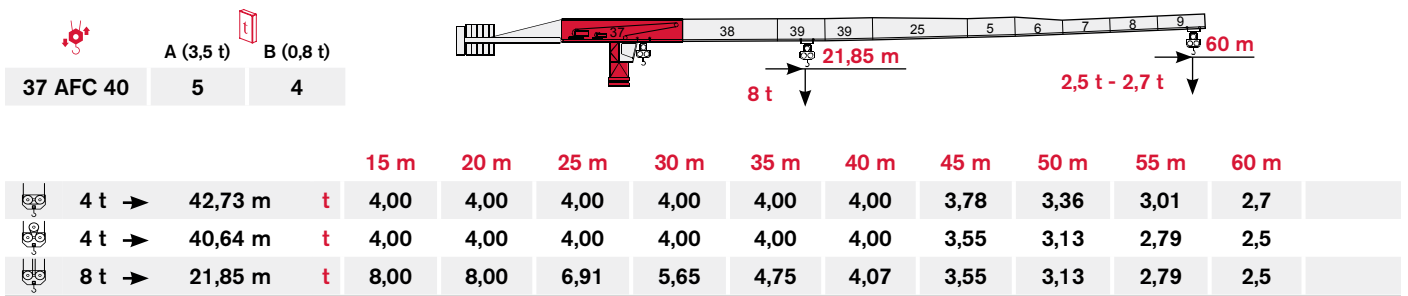
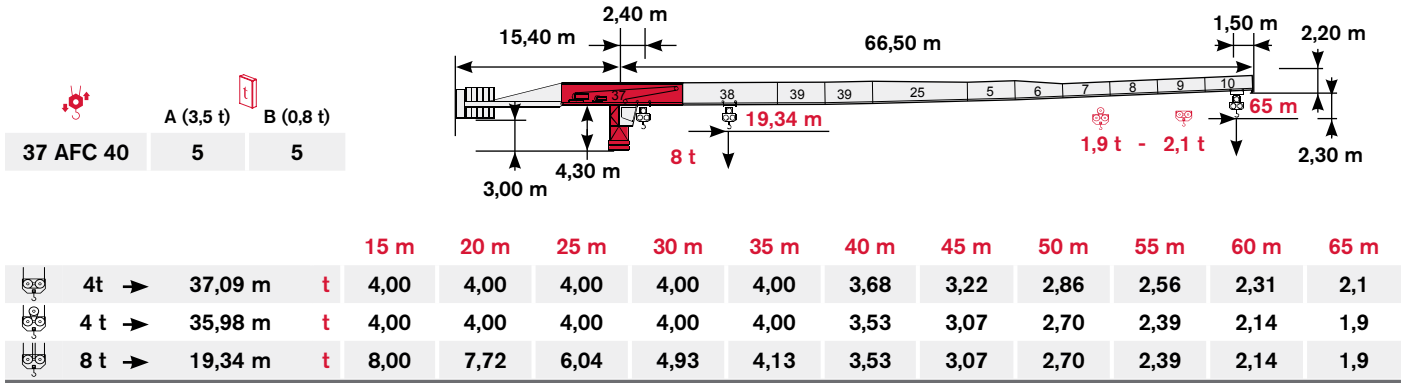

LOAD DIAGRAM

Lastkurven · Courbes de charges · Curvas de cargas · Diagramma di portata · Diagrama de carga · Диаграмма грузоподъёмности



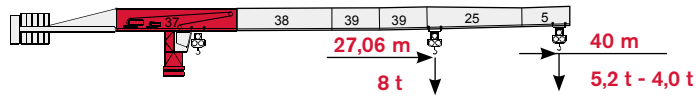



	A (3,5 t)	B (0,8 t)
37 AFC 40	4	3

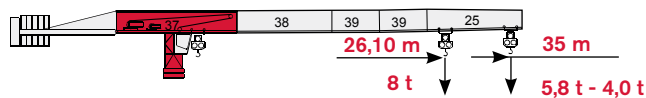

			15 m	20 m	25 m	30 m	35 m	40 m						
	4 t →	40,00 m	t	4,00	4,00	4,00	4,00	4,00	4,0					
	4 t →	40,00 m	t	4,00	4,00	4,00	4,00	4,00	4,0					
	8 t →	27,06 m	t	8,00	8,00	8,00	7,15	6,04	5,2					



	A (3,5 t)	B (0,8 t)
37 AFC 40	4	1



			15 m	20 m	25 m	30 m	35 m							
	4 t →	35,00 m	t	4,00	4,00	4,00	4,00	4,0						
	4 t →	35,00 m	t	4,00	4,00	4,00	4,00	4,0						
	8 t →	26,10 m	t	8,00	8,00	8,00	6,88	5,8						

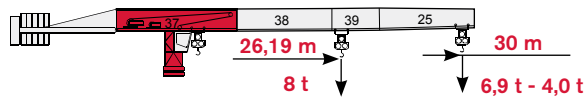

	A (3,5 t)	B (0,8 t)
37 AFC 40	3	3

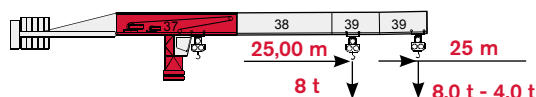

			15 m	20 m	25 m	30 m								
	4 t →	30,00 m	t	4,00	4,00	4,00	4,0							
	4 t →	30,00 m	t	4,00	4,00	4,00	4,0							
	8 t →	26,19 m	t	8,00	8,00	8,00	6,9							

	A (3,5 t)	B (0,8 t)
37 AFC 40	3	1



			15 m	20 m	25 m									
	4 t →	25,00 m	t	4,00	4,00	4,0								
	4 t →	25,00 m	t	4,00	4,00	4,0								
	8 t →	25,00 m	t	8,00	8,00	8,0								

LOAD DIAGRAM

Lastkurven · Courbes de charges · Curvas de cargas · Diagramma di portata · Diagrama de carga · Диаграмма грузоподъёмности

TEREX POWER PLUS

	A (3,5 t)	B (0,8 t)
37 AFC 40	5	5

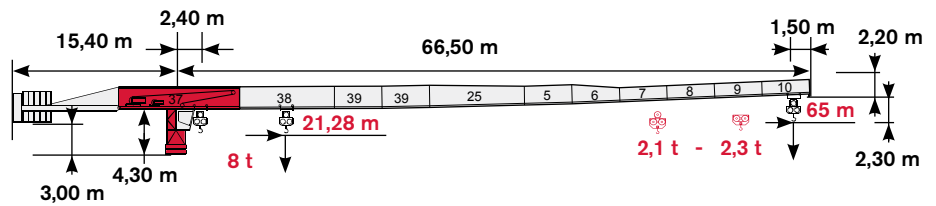

			15 m	20 m	25 m	30 m	35 m	40 m	45 m	50 m	55 m	60 m	65 m		
	4 t →	40,80 m	t	4,00	4,00	4,00	4,00	4,00	4,00	3,59	3,19	2,86	2,58	2,33	T P P
	4 t →	39,58 m	t	4,00	4,00	4,00	4,00	4,00	3,95	3,44	3,03	2,70	2,42	2,13	
	8 t →	21,28 m	t	8,00	8,00	6,71	5,48	4,61	3,95	3,44	3,03	2,70	2,42	2,13	

	A (3,5 t)	B (0,8 t)
37 AFC 40	5	4

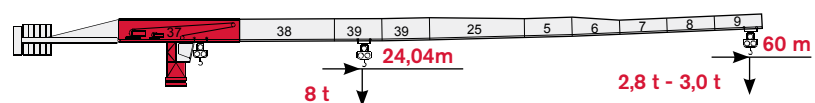

			15 m	20 m	25 m	30 m	35 m	40 m	45 m	50 m	55 m	60 m		
	4 t →	47,00 m	t	4,00	4,00	4,00	4,00	4,00	4,00	4,00	3,73	3,36	3,03	T P P
	4 t →	44,71 m	t	4,00	4,00	4,00	4,00	4,00	4,00	3,97	3,51	3,13	2,77	
	8 t →	24,04 m	t	8,00	8,00	7,67	6,28	5,29	4,55	3,97	3,51	3,13	2,77	

	A (3,5 t)	B (0,8 t)
37 AFC 40	5	3

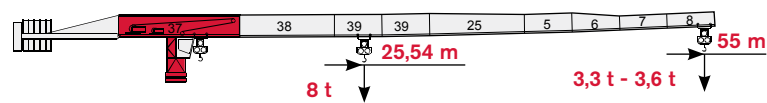

			15 m	20 m	25 m	30 m	35 m	40 m	45 m	50 m	55 m		
	4 t →	49,56 m	t	4,00	4,00	4,00	4,00	4,00	4,00	4,00	3,96	3,55	T P P
	4 t →	47,49 m	t	4,00	4,00	4,00	4,00	4,00	4,00	4,00	3,77	3,33	
	8 t →	25,54 m	t	8,00	8,00	8,00	6,71	5,66	4,87	4,26	3,77	3,33	

	A (3,5 t)	B (0,8 t)
37 AFC 40	5	2

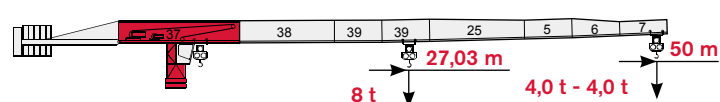

			15 m	20 m	25 m	30 m	35 m	40 m	45 m	50 m		
	4 t →	50,00 m	t	4,00	4,00	4,00	4,00	4,00	4,00	4,00		T P P
	4 t →	50,00 m	t	4,00	4,00	4,00	4,00	4,00	4,00	4,00		
	8 t →	27,03 m	t	8,00	8,00	8,00	7,14	6,03	5,19	4,54	4,00	

	A (3,5 t)	B (0,8 t)
37 AFC 40	5	0

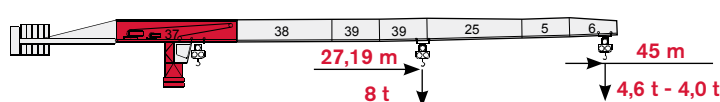

			15 m	20 m	25 m	30 m	35 m	40 m	45 m		
	4 t →	45,00 m	t	4,00	4,00	4,00	4,00	4,00	4,00		T P P
	4 t →	45,00 m	t	4,00	4,00	4,00	4,00	4,00	4,00		
	8 t →	27,19 m	t	8,00	8,00	8,00	7,19	6,07	5,23	4,55	

TOWER

Turn · Tour · Torre · Torre · Torre · Башня

Standard Configurations · Standardkonfiguration · Standard Implantations ·
 Implantaciones Standard · Installazioni Standard · Configuração padrão ·
 Стандартная конфигурация крана

TS16

Tower: TS16 & Basement: R1

	●	◊
R1	-1620 kN	-1940 kN
R2	1270 kN	1590 kN
	470 kN	

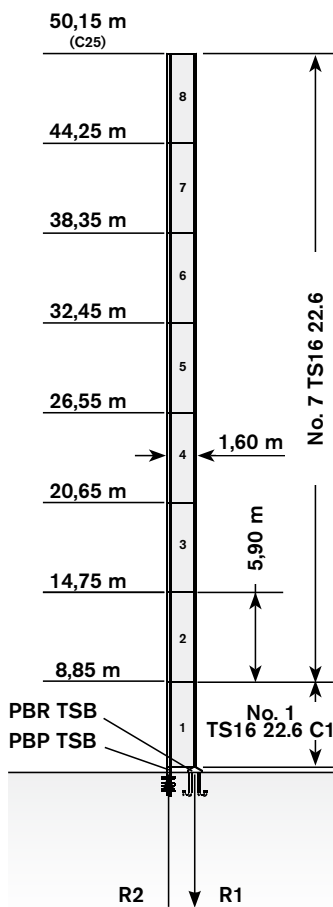

	max. H (m)	
	FEM 1001	FEM 1005 C25
25->45 m	50,15	50,15
50->65 m	50,15	50,15

Tower: TS16 & Basement: F1

	●	◊
R1	-1070 kN	-1320 kN
R2	0 kN	0 kN
	510 kN	

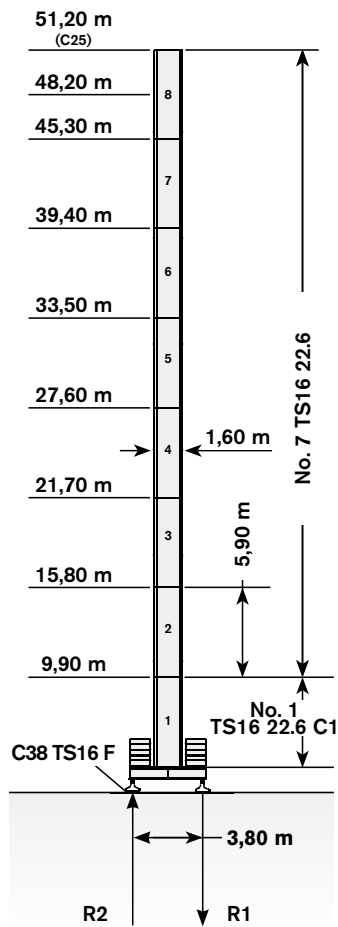

	max. H (m)	
	FEM 1001	FEM 1005 C25
25->45 m	48,20	48,20
50->65 m	51,20	51,20

Tower: TS16 & Basement: FP1

	●	◊
R1	-1070 kN	-1320 kN
R2	0 kN	0 kN
	510 kN	

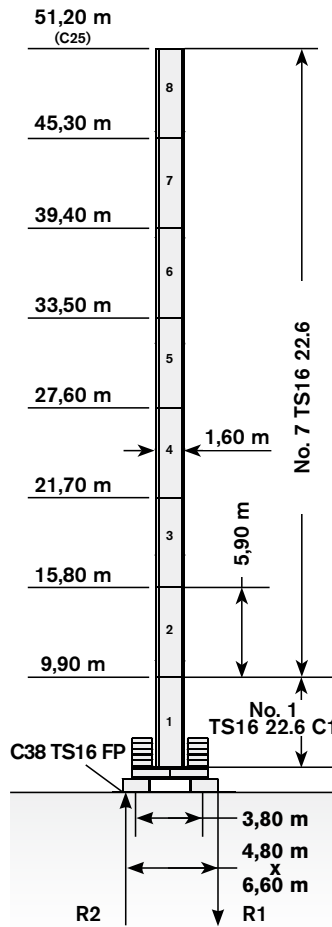

	max. H (m)	
	FEM 1001	FEM 1005 C25
25->45 m	51,20	51,20
50->65 m	51,20	51,20

Tower: TS16 & Basement: T1

	●	◊
R1	-1130 kN	-1140 kN
R2	0 kN	0 kN
	490 kN	

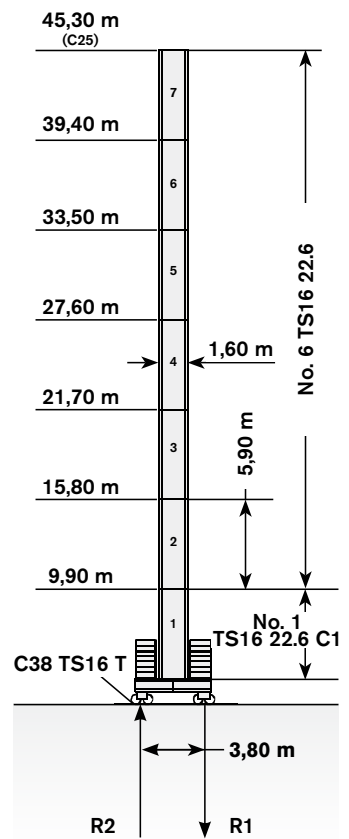

	max. H (m)	
	FEM 1001	FEM 1005 C25
25->45 m	45,30	45,30
50->65 m	45,30	45,30

Max. under hook height · Höchste Hakenhöhe · Hauteur maxi. sous crochet · Maxima altura bajo gancho · Altezza max. sotto gancio ·
 Alt. máx. sob o gancho · Макс высота крюка

Different heights and tower combinations are available; please consult us · Andere Höhen und Turmkombinationen auf Anfrage · Différentes
 hauteurs et combinaisons de tour sont disponibles; nous consulter · Hay diferentes alturas y combinaciones de torre disponibles. Consúltenos
 · Altezze diverse e combinazioni di torre sono disponibili; consultateci · Diferentes alturas e combinações de torres disponíveis; fale conosco ·
 Возможны другие сочетания высоты и конфигурации башни; проконсультируйтесь с нами

Tower: TS16 & Basement: F2

	●	◆
R1	-910 kN	-1130 kN
R2	0 kN	0 kN
	530 kN	

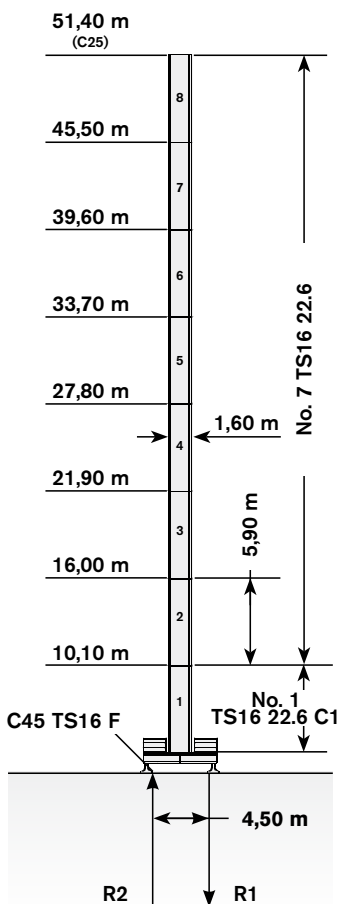

	max. H (m)	
	FEM 1001	FEM 1005 C25
25->45 m	51,40	51,40
50->65 m	51,40	51,40

Tower: TS16 & Basement: FP2

	●	◆
R1	-910 kN	-1130 kN
R2	0 kN	0 kN
	530 kN	

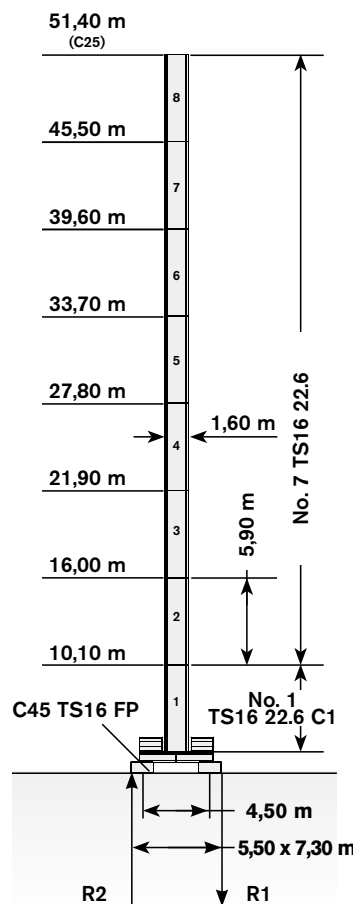

	max. H (m)	
	FEM 1001	FEM 1005 C25
25->45 m	51,40	51,40
50->65 m	51,40	51,40

Tower: TS16 & Basement: T2

	●	◆
R1	-960 kN	-980 kN
R2	0 kN	0 kN
	510 kN	

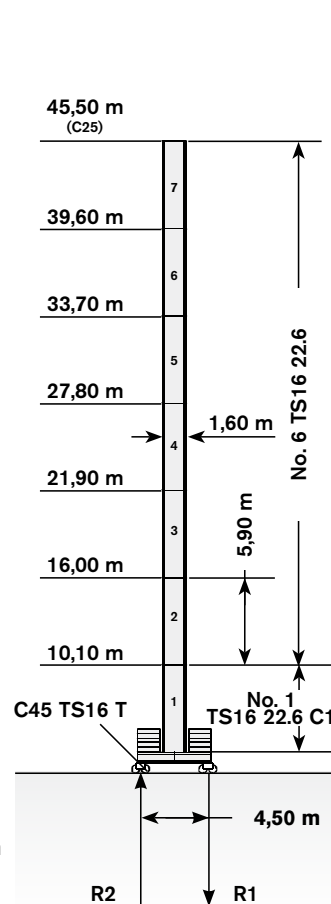

	max. H (m)	
	FEM 1001	FEM 1005 C25
25->45 m	45,50	45,50
50->65 m	45,50	45,50

The available lengths for the TS tower sections are 11.8 m, 5.9 m, 2.95 m. · Die Turmschüsse TS sind mit Längen 11.8 m, 5.9 m, 2.95 m verfügbar. · Les éléments de mât TS sont disponibles en longueur 11.8 m, 5.9 m, 2.95 m. · Los tramos de torre TS son disponibles en las medidas de largo 11.8 m, 5.9 m, 2.95 m. · Le prolunghe TS sono disponibili in lunghezza 11.8 m, 5.9 m, 2.95 m. · Os comprimentos disponíveis para elementos de torre TS são: 11.8m, 5.9m e 2.95m. · Длина поставляемых секций башни TS - 11.8 m, 5.9 m, 2.95 m.

TOWER

Turn · Tour · Torre · Torre · Torre · Башня

Standard Configurations · Standardkonfiguration · Standard Implantations ·
 Implantaciones Standard · Installazioni Standard · Configuração padrão ·
 Стандартная конфигурация крана

TS21

Tower: TS21 & Basement: R2

R1	-1620 kN	-2080 kN
R2	1190 kN	1710 kN
	740 kN	

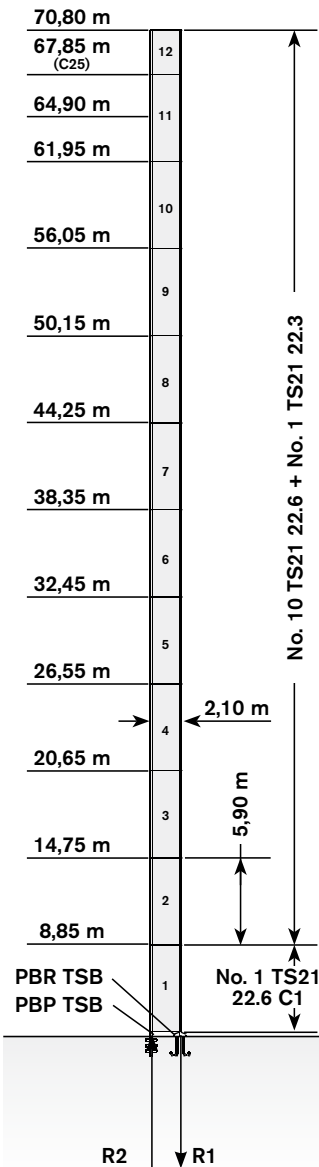

Tower: TS21 & Basement: F3

R1	-940 kN	-1320 kN
R2	-30 kN	0 kN
	590 kN	

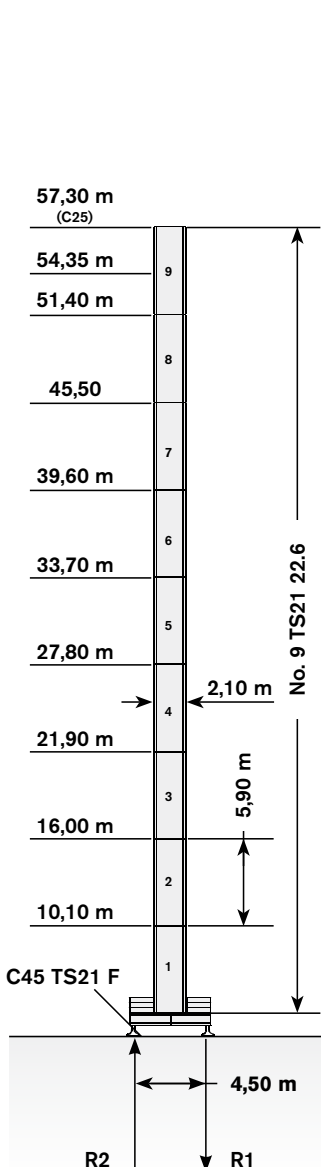

Tower: TS21 & Basement: FP3

R1	-1010 kN	-1410 kN
R2	-42 kN	0 kN
	600 kN	

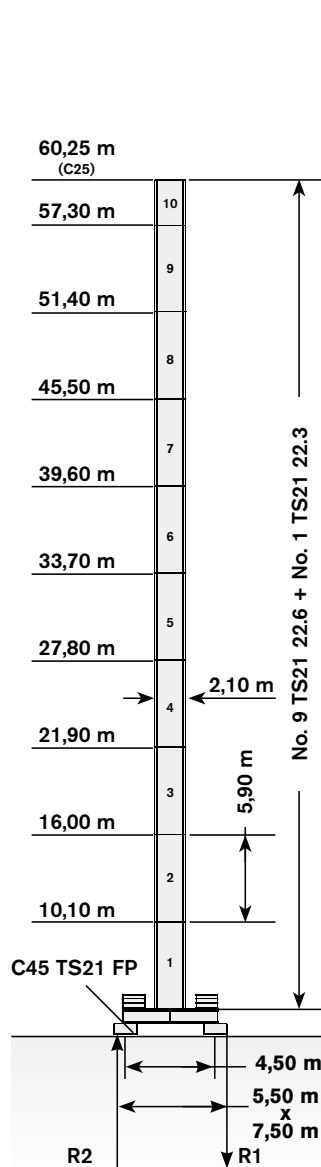

Tower: TS21 & Basement: T3

R1	-1070 kN	-1320 kN
R2	0 kN	4460 kN
	590 kN	

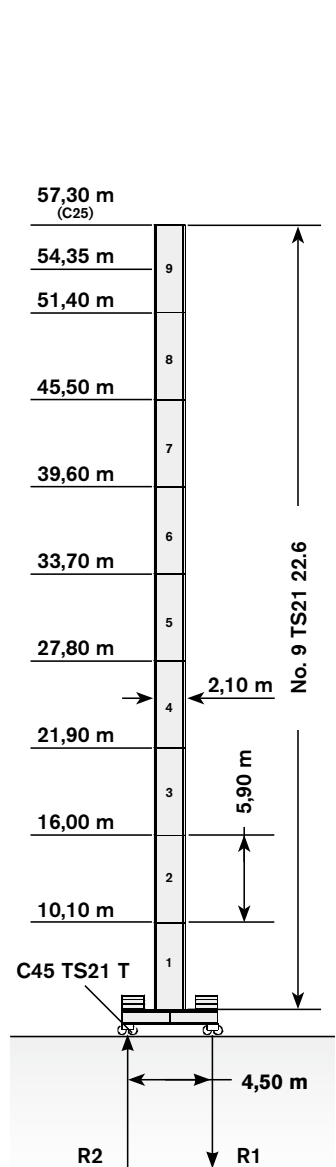

Max. under hook height · Höchste Hakenhöhe · Hauteur maxi. sous crochet · Maxima altura bajo gancho · Altezza max. sotto gancio ·
 Alt. máx. sob o gancho · Макс высота крюка

Tower: TS21 & Basement: F4

	●	◆
R1	-880 kN	-1130 kN
R2	-60 kN	0 kN
	660 kN	

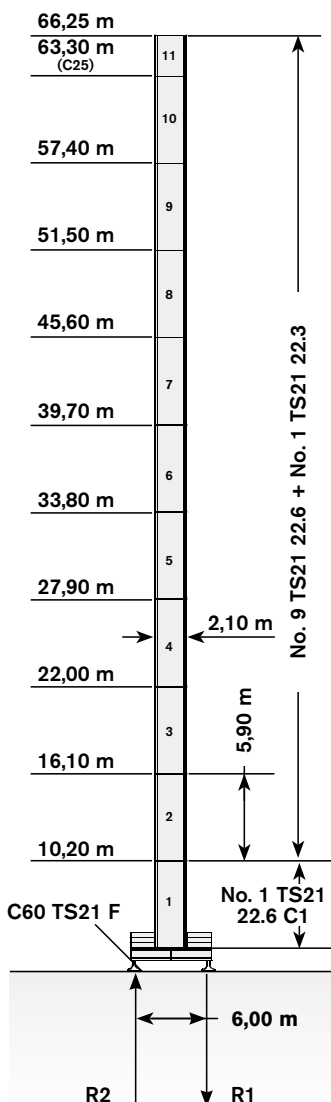

	max. H (m)	
	FEM 1001	FEM 1005 C25
25->45 m	66,25	63,30
50->65 m	66,25	63,30

Tower: TS21 & Basement: FP4

	●	◆
R1	-970 kN	-1220 kN
R2	-60 kN	0 kN
	680 kN	

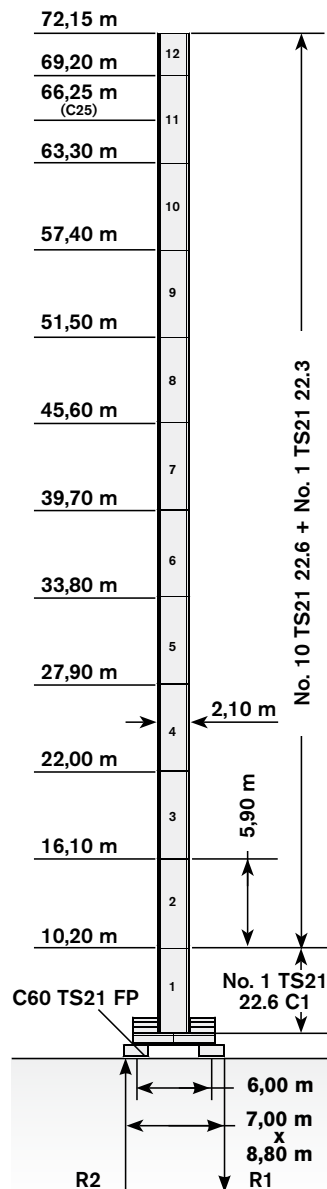

	max. H (m)	
	FEM 1001	FEM 1005 C25
25->45 m	72,15	66,25
50->65 m	72,15	63,30

Tower: TS21 & Basement: T4

	●	◆
R1	-940 kN	-1130 kN
R2	0 kN	0 kN
	640 kN	

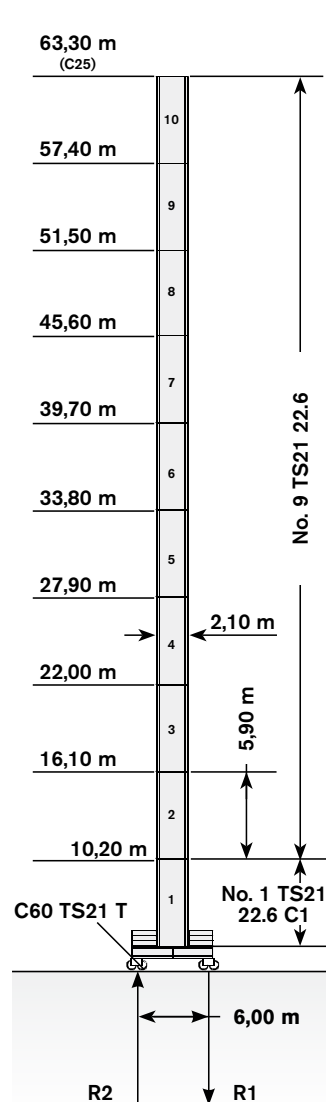

	max. H (m)	
	FEM 1001	FEM 1005 C25
25->45 m	63,30	63,30
50->65 m	63,30	63,30

The available lengths for the TS tower sections are 11.8 m, 5.9 m, 2.95 m. · Die Turmschüsse TS sind mit Längen 11.8 m, 5.9 m, 2.95 m verfügbar. · Les éléments de mât TS sont disponibles en longueur 11.8 m, 5.9 m, 2.95 m. · Los tramos de torre TS son disponibles en las medidas de largo 11.8 m, 5.9 m, 2.95 m. · Le prolunghe TS sono disponibili in lunghezza 11.8 m, 5.9 m, 2.95 m. · Os comprimentos disponíveis para elementos de torre TS são: 11.8m, 5.9m e 2.95m. · Длина поставляемых секций башни TS - 11.8 м, 5.9 м, 2.95 м.

TOWER

Turn · Tour · Torre · Torre · Torre · Башня

Standard Configurations · Standardkonfiguration · Standard Implantations ·
 Implantaciones Standard · Installazioni Standard · Configuração padrão ·
 Стандартная конфигурация крана

H20

Tower: H20 & Basement: RTL

R1	-2024 kN	-3333 kN
R2	1435 kN	2829 kN
	1057 kN	

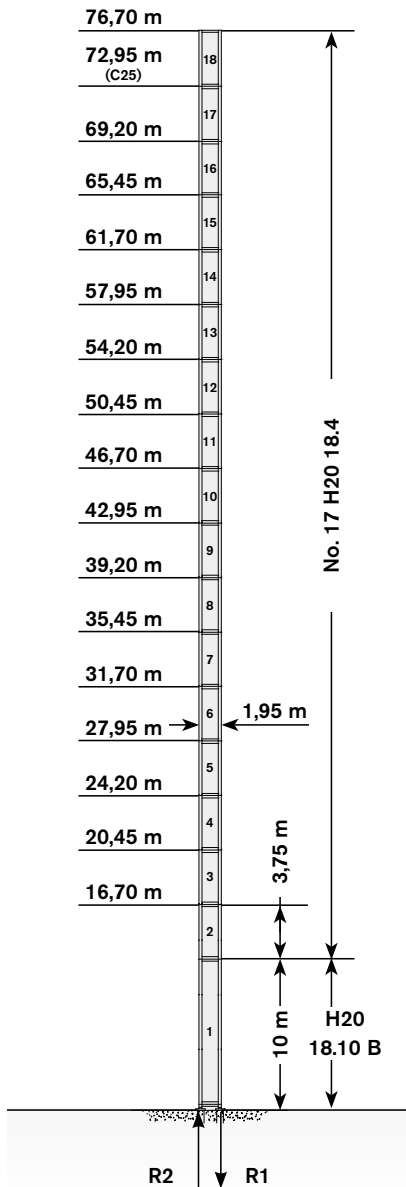

Tower: H20 & Basement: FTR

R1	-1173 kN	-1711 kN
R2	-346 kN	0 kN
	1098 kN	

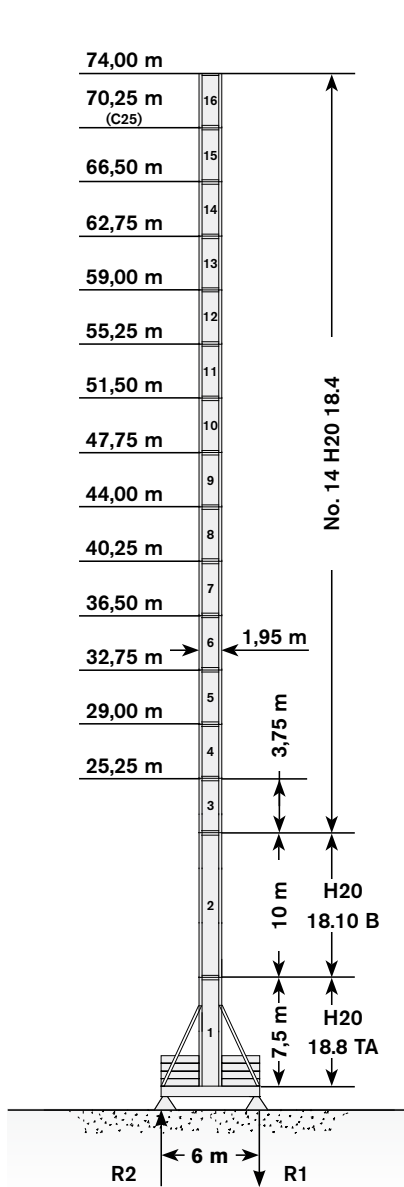

Tower: H20 & Basement: TTR

R1	-1083 kN	-1268 kN
R2	-111 kN	0 kN
	1038 kN	

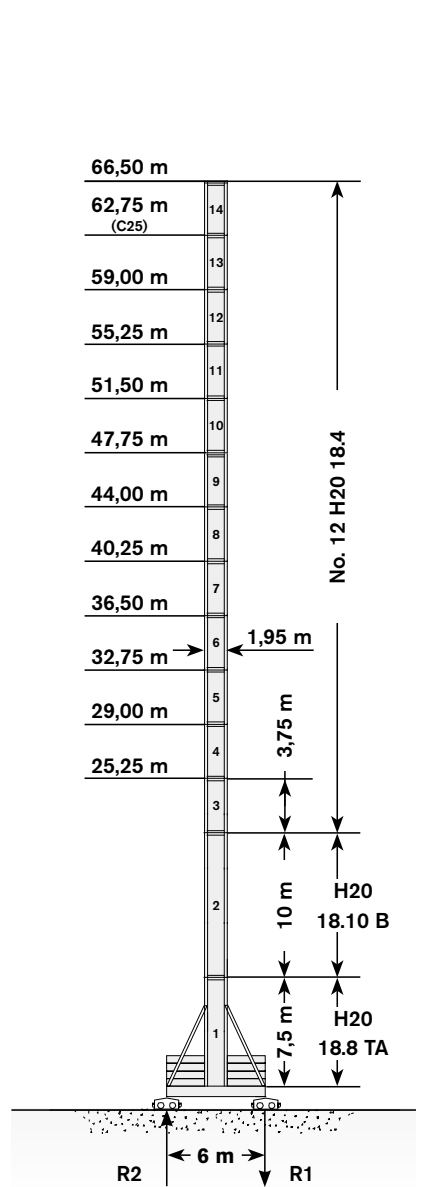

Max. under hook height · Höchst Hakenhöhe · Hauteur maxi. sous crochet · Maxima altura bajo gancho · Altezza max. sotto gancio · alt. máx. sob o gancho · МАКС ВЫСОТА КРЮКА

Different heights and tower combinations are available; please consult us · Andere Höhen und Turmkombinationen auf Anfrage · Différentes hauteurs et combinaisons de tour sont disponibles; nous consulter · Hay diferentes alturas y combinaciones de torre disponibles. Consúltenos · Altezze diverse e combinazioni di torre sono disponibili; consultateci · Diferentes alturas e combinações de torres disponíveis; fale conosco · Возможны другие сочетания высоты и конфигурации башни; проконсультируйтесь с нами



Other configurations · Aufstellmöglichkeiten · Autres Implantations · Otras Implantaciones · Altre Installazioni · Outras configurações · Другие конфигурации

Bottom climbing crane · Kletterkran im Gebäude · Télescopage sur dalles · Telescopage grúa trepadora · Gru climbing · Guindaste automontante interno · Самоподъемный кран

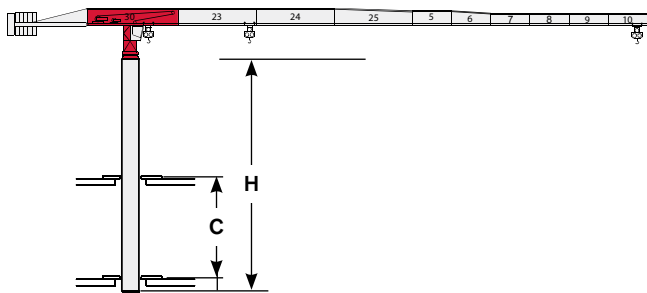

Crane tied to the structure · Geankerter Kran · Grue ancrée · Grúa anclada · Gru ancorata · Guindaste ancorado na estrutura · Кран, крепящийся к сооружению

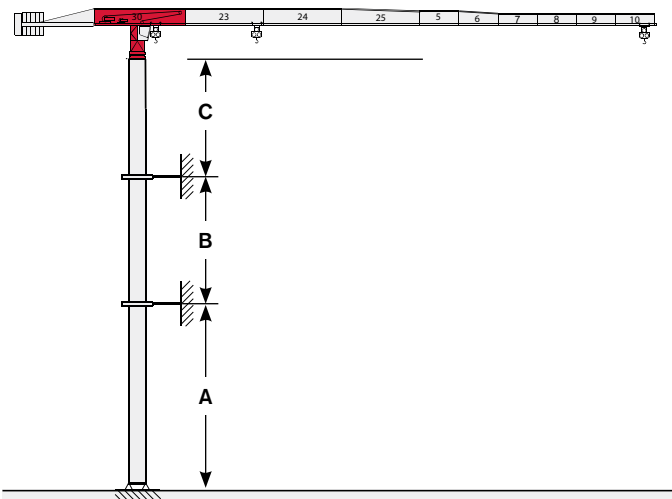

Tower: TS16

Jib	C min/max (m)	H min/max (m)
		i

Tower: TS16

Jib	A min/max (m)	B min/max (m)	C max (m)
all			i

Tower: TS21

Jib	C min/max (m)	H min/max (m)
all	11/14	29,5/41,3

Tower: TS21

Jib	A min/max (m)	B min/max (m)	C max (m)
all	48/54	23/32	35

Tower: H20

Jib	C min/max (m)	H min/max (m)
all		i

Tower: H20

Jib	A min/max (m)	B min/max (m)	C max (m)
all	48/54	18/28	40



Different heights and tower combinations are available; please consult us · Andere Höhen und Turmkombinationen auf Anfrage · Différentes hauteurs et combinaisons de tour sont disponibles; nous consulter · Hay diferentes alturas y combinaciones de torre disponibles. Consúltenos · Altezze diverse e combinazioni di torre sono disponibili; consultateci · Diferentes alturas e combinações de torres disponíveis; fale conosco · Возможны другие сочетания высоты и конфигурации башни; проконсультируйтесь с нами

MECHANISMS

Antriebe · Mécanismes · Mecanismos · Meccanismi · Mecanismo · Механизм

Power supply · Stromversorgung · Alimentation · Suministro eléctrico · Alimentazione · Requisitos de energia · Требования по питанию

	37 AFC 40	93 kVA*	400V - 50Hz / 460V - 60Hz	2000/14/CE modificata
--	-----------	---------	---------------------------	-----------------------

* Average consumption · Durchschnittsverbrauch · Consommation moyenne · Consumo medio · Consumo medio · Consumo médio · Среднее потребление

Hoisting · Heben · Levage · Elevación · Sollevamento · Elevação · Подъем

			t	m/min	kW	
	37 AFC 40		4	0 → 44	37	
			3	0 → 57		
			2	0 → 82		
			1,5	0 → 105		
			1	0 → 132		
			8	0 → 22		
			6	0 → 28		
			4	0 → 41		
			3	0 → 52		
			2	0 → 66		

Hoisting Speed · Heben Geschwindigkeit · Vitesse de Levage · Velocidad de Elevación · Velocità di Sollevamento · Velocidade de içamento · Скорость подъема

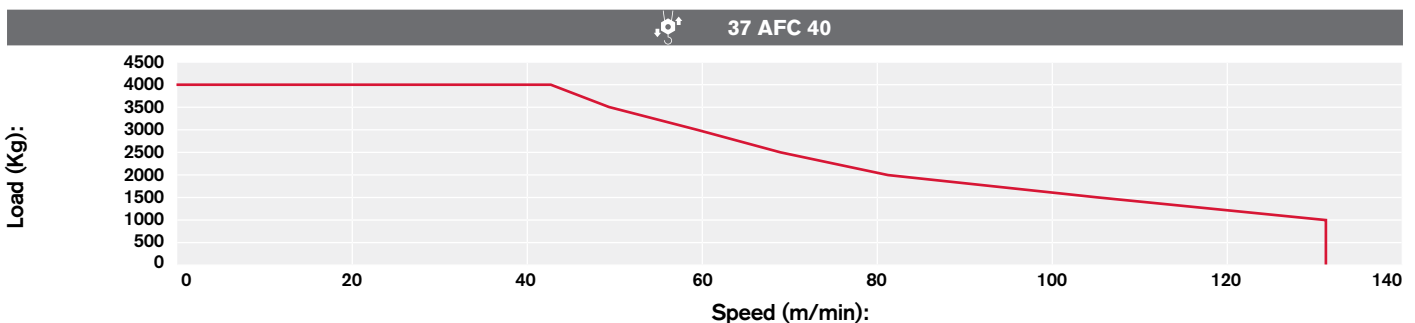

Additional Specifications · Weitere Leistungsdaten · Spécifications additionnelles · Otras prestaciones · Altre movimentazioni · Especificações adicionais · Дополнительные спецификации

	DVF 3 6	0 → 40 → 80 m/min	5,5 kW
	SVF 2 2 6	0,7 r.p.m	2 x 5,5 kW
	TAD 2RP 2M4	0 → 24 m/min	2 x 4 kW
	TAD 2RG 4M3	0 → 24 m/min	4 x 3 kW
	i		

Tower height max.

		T3	T4
	TAD 2RP 2M4	39,10 m	32,90 m
	TAD 2RG 4M3	> 39,10 m	> 32,90 m



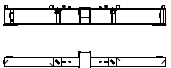
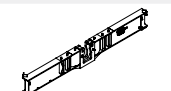
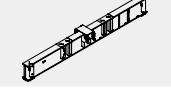
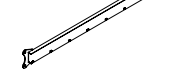
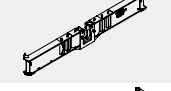
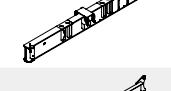
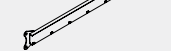

Packing list

Undercarriage

CTT 202-8	DESCRIPTION · BESCHREIBUNG · DESCRIPTION · DESCRIPCIÓN · DESCRIZIONE · DESCRIÇÃO · ОПИСАНИЕ	LENGTH · LÄNGE · LONGUEUR · LONGITUD · LUNGHEZZA · COMPRIMENTO · ДЛИНА	WIDTH · BREITE · LARGEUR · ANCHURA · LARGHEZZA · LARGURA · ШИРИНА	HEIGHT · HÖHE · HAUTEUR · ALTURA · ALTEZZA · ALTURA · ВЫСОТА	QUANTITY · MENGE · QUANTITÉ · CANTIDAD · QUANTITÀ · QUANTIDADE · КОЛИЧЕСТВО	WEIGHT · GEWICHT · POIDS · PESO · PESO · ВЕС
	UNDERCARRIAGE C38 TS16 BEAM "A"	5,8 m	0,41 m	0,8 m	1	2050 kg
	UNDERCARRIAGE C38 TS16 BEAM "B"	5,8 m	0,75 m	0,7 m	1	2050 kg
	UNDERCARRIAGE C38 TS16 CROSSBEAM (T)	3,7 m	0,11 m	0,4 m	1	190 kg
	BEAM "A" FOR UNDERCARRIAGE C45 TS21-TS16	6,80 m	0,40 m	1,00 m	1	2820 kg
	BEAM "B" FOR UNDERCARRIAGE C45 TS21-TS16	6,80 m	0,75 m	0,80 m	1	2620 kg
	CROSSBEAMS UNDERCARRIAGE C45 TS21-TS16 (T)	4,40 m	0,12 m	0,54 m	2	230 kg
	"A" BEAM FOR UNDERCARRIAGE C60	8,90 m	0,40 m	1,10 m	1	3600 kg
	"B" BEAM FOR UNDERCARRIAGE C60	8,90 m	0,70 m	0,90 m	1	3600 kg
	CROSSBEAM FOR UNDERCARRIAGE C60 (T)	5,90 m	0,60 m	0,20 m	2	450 kg

Tower

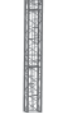







CTT 202-8 TS16

	TOWER SECTION TS16 22.3	1,6 m	1,60 m	2,98 m	1	1215 kg*
	TOWER SECTION TS16 22.6	1,6 m	1,6 m	5,93 m	1	2260 kg*
	TOWER SECTION TS16 22.12	1,6 m	1,6 m	11,83 m	1	4400 kg*
	SLEWING UNIT TS16	2,01 m	1,99 m	1,63 m	1	4400 kg

* Completewithladder,supportandladderguard,platform

TRANSPORTATION

Transport · Transport · Transporte · Trasporto · Transporte · Транспортировка









CTT 202-8 TS21	DESCRIPTION · BESCHREIBUNG · DESCRIPTION · DESCRIPCIÓN · DESCRIZIONE · DESCRIÇÃO · ОПИСАНИЕ	LENGTH · LÄNGE · LONGUEUR · LONGITUD · LUNGHEZZA · COMPRIMENTO · ДЛИНА	WIDTH · BREITE · LARGEUR · ANCHURA · LARGHEZZA · LARGURA · ШИРИНА	HEIGHT · HÖHE · HAUTEUR · ALTURA · ALTEZZA · ALTURA · ВЫСОТА	QUANTITY · MENGE · QUANTITÉ · CANTIDAD · CANTITÀ · QUANTIDADE · КОЛИЧЕСТВО	WEIGHT · GEWICHT · POIDS · PESO · PESO · ВЕС
	TS21 22.3 TOWER SECTION	2,10 m	2,10 m	2,98 m	1	1382 kg*
	TS21 22.6 TOWER SECTION	2,10 m	2,10 m	5,93 m	1	2550 kg*
	TS21 22.12 TOWER SECTION	2,07 m	2,10 m	11,80 m	1	4825 kg
	TS21 22.6 C1 TOWER SECTION	2,10 m	2,10 m	5,93 m	1	2800 kg*
	TS21 22.6 C2 TOWER SECTION	2,10 m	2,10 m	5,93 m	1	2611 kg*
	SLEWING UNIT TS21	2,21 m	2,49 m	1,63 m	1	5200 kg
CTT 202-8 H20						
	TOWER SECTION HA20 18.10 B	10 m	2 m	1,95 m	1	7000 kg*
	TOWER SECTION HA20 18.4 B	3,75 m	2 m	1,95 m	1	2955 kg*
	SLEWING UNIT H20	2,26 m	2,26 m	2,06 m	1	5530 kg

* Complete with ladders, platforms and assembly equipment

Cab





CTT 202-8	DESCRIPTION · BESCHREIBUNG · DESCRIPTION · DESCRIPCIÓN · DESCRIZIONE · DESCRICÃO · ОПИСАНИЕ	LENGTH · LÄNGE · LONGUEUR · LONGITUD · LUNGHEZZA · COMPRIMENTO · ДЛИНА	WIDTH · BREITE · LARGEUR · ANCHURA · LARGHEZZA · LARGURA · ШИРИНА	HEIGHT · HÖHE · HAUTEUR · ALTURA · ALTEZZA · ALTURA · ВЫСОТА	QUANTITY · MENGE · QUANTITÉ · CANTIDAD · CANTIDAD · QUANTITÀ · QUANTIDADE · КОЛИЧЕСТВО	WEIGHT · GEWICHT · POIDS · PESO · PESO · ВЕС
	CAB SECTION	1,82 m	1,38 m	3,50 m	1	2000 kg
	CAB UNIT PLATFORM	3,30 m	1,80 m	2,40 m	1	1230 kg

Upper Part

	JIB SECTION 37	11,9 m	1,77 m	2,33 m	1	6500 kg
	JIB SECTION - 38	10,3 m	1,11 m	2,23 m	1	2400 kg
	JIB SECTION - 39	5,30 m	1,11 m	2,20 m	1	1010 kg
	JIB SECTION-25	10,3 m	1,11 m	1,80 m	1	1408 kg
	JIB SECTION-05	5,20 m	1,11 m	1,80 m	1	530 kg
	JIB SECTION-06	5,20 m	1,11 m	1,80 m	1	510 kg
	JIB SECTION-07	5,2 m	1,11 m	1,3 m	1	450 kg
	JIB SECTION-08	5,2 m	1,11 m	1,30 m	1	400 kg

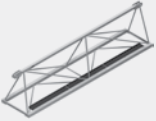
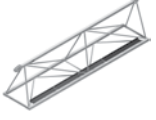
TRANSPORTATION

Transport · Transport · Transporte · Trasporto · Transporte · Транспортировка

CTT 202-8	DESCRIPTION · BESCHREIBUNG · DESCRIPTION · DESCRIPCIÓN · DESCRIZIONE · DESCRICÃO · ОПИСАНИЕ	LENGTH · LÄNGE · LONGUEUR · LONGITUD · LUNGHEZZA · COMPRIMENTO · ДЛИНА	WIDTH · BREITE · LARGEUR · ANCHURA · LARGHEZZA · LARGURA · ШИРИНА	HEIGHT · HÖHE · HAUTEUR · ALTURA · ALTEZZA · ALTURA · ВЫСОТА	QUANTITY · MENGE · QUANTITÉ · CANTIDAD · QUANTITÀ · QUANTIDADE · КОЛИЧЕСТВО	WEIGHT · GEWICHT · POIDS · PESO · PESO · ВЕС
	JIB SECTION-09	5,2 m	1,11 m	1,30 m	1	300 kg
	JIB SECTION-10	5,2 m	1,11 m	1,30 m	1	285 kg
	COUNTERJIB	9,70 m	1,40 m	0,80 m	1	2300 kg
	JIB TROLLEY AND HOIST BLOCKS	1,35 m	1,60 m	0,90 m	1	598 kg
	HOIST BLOCK	0,85 m	0,36 m	0,95 m	1	328 kg
	QEG GENERAL ELECTRICAL BOX PLATFORM	2,38 m	1,57 m	1,78 m	1	770 kg

FONTANAFREDDA

Via delle Innovazioni, 17
33074 Fontanafredda (PN)
Italy

Ph: +39 0434 989 111
Fax: +39 0434 989 631

Effective Date: February 2019

Product specifications and prices are subject to change without notice or obligation. The photographs and/or drawings in this document are for illustrative purposes only. Refer to the appropriate Operator's Manual for instructions on the proper use of this equipment. Failure to follow the appropriate Operator's Manual when using our equipment or to otherwise act irresponsibly may result in serious injury or death. The only warranty applicable to our equipment is the standard written warranty applicable to the particular product and sale and Terex makes no other warranty, express or implied. Products and services listed may be trademarks, service marks or trade-names of Terex Corporation and/or its subsidiaries in the USA and other countries. All rights are reserved. Terex® is a registered trademark of Terex Corporation in the USA and many other countries.

Gültig ab: Februar 2019

Produktbeschreibungen und Preise können jederzeit und ohne Verpflichtung zur Ankündigung geändert werden. Die in diesem Dokument enthaltenen Fotos und/oder Zeichnungen dienen rein anschaulichen Zwecken. Anweisungen zur ordnungsgemäßen Verwendung dieser Ausrüstung entnehmen Sie bitte dem zugehörigen Betriebshandbuch. Nichtbefolgung des Betriebshandbuchs bei der Verwendung unserer Produkte oder anderweitig fahrlässiges Verhalten kann zu schwerwiegenden Verletzungen oder Tod führen. Für dieses Produkt wird ausschließlich die entsprechende, schriftlich niedergelegte Standardgarantie gewährt. Terex leistet keinerlei darüber hinaus gehende Garantie, weder ausdrücklich noch stillschweigend. Die Bezeichnungen der aufgeführten Produkte und Leistungen sind gegebenenfalls Marken, Servicemarken oder Handelsnamen der Terex Corporation und/oder ihrer Tochtergesellschaften in den USA und anderen Ländern. Alle Rechte vorbehalten. „TEREX“ ist eine eingetragene Marke der Terex Corporation in den USA und vielen anderen Ländern.

Date d'effet : Février 2019

Les spécifications et prix des produits sont sujets à modification sans avis ou obligation. Les photographies et/ou dessins contenus dans ce documents sont uniquement pour illustration. Veuillez vous référer à la notice d'utilisation appropriée pour les instructions quant à l'utilisation correcte de cet équipement. Tout manquement au suivi de la notice d'utilisation appropriée lors de l'utilisation de notre équipement ou tout acte autrement irresponsable peut résulter en blessure corporelle sérieuse ou mortelle. La seule garantie applicable à notre équipement est la garantie standard écrite applicable à un produit et à une vente spécifique. Terex n'offre aucune autre garantie, expresse ou explicite. Les produits et services proposés peuvent être des marques de fabrique, des marques de service ou des appellations commerciales de Terex Corporation et/ou ses filiales aux Etats Unis et dans les autres pays, et tous les droits sont réservés. «TEREX» est une marque déposée de Terex Corporation aux Etats Unis et dans de nombreux autres pays.

Fecha efectiva: Febrero 2019

Los precios y las especificaciones de productos pueden sufrir cambios sin aviso previo u obligación. Las fotografías o dibujos de este documento tienen un fin meramente ilustrativo. Consulte el manual de instrucciones del operador correspondiente para más información sobre el uso correcto de este equipo. El hecho de no respetar el manual del operador correspondiente al utilizar el equipo o actuar de forma irresponsable puede suponer lesiones graves o fatales. La única garantía aplicable a nuestro equipo es la garantía escrita estándar correspondiente a cada producto y venta, y TEREX no amplía dicha garantía de forma expresa o implícita. Los productos y servicios mencionados pueden ser marcas registradas, marcas de servicio o nombres de marca de TEREX Corporation o de sus filiales en Estados Unidos de América y otros países, y se reservan todos los derechos. „TEREX“ es una marca comercial registrada de Terex Corporation en Estados Unidos de América y muchos otros países.

Data di inizio validità: Febbraio 2019

Ci riserviamo il diritto di modificare le specifiche e i prezzi dei prodotti in ogni momento e senza preavviso. Le fotografie e/o i disegni contenuti in questo documento sono destinati unicamente a scopi illustrativi. Consultare le istruzioni sull'uso corretto di questo macchinario, contenute nell'opportuno Manuale dell'operatore. L'inottemperanza delle istruzioni contenute nel Manuale dell'operatore del macchinario e altri comportamenti irresponsabili possono provocare gravi lesioni, anche mortali. L'unica garanzia applicabile ai nostri macchinari è la garanzia scritta standard applicabile al particolare prodotto e alla particolare vendita; Terex è esonerata dal fornire qualsiasi altra garanzia, esplicita o implicita. I prodotti e servizi elencati possono essere dei marchi di fabbrica, marchi di servizio o nomi commerciali di TEREX Corporation e/o società affiliate negli Stati Uniti d'America e altre nazioni e tutti i diritti sono riservati. „TEREX“ è un marchio registrato di Terex Corporation negli USA e molti altri Paesi.

Data de vigência: Fevereiro 2019

Especificações e preços dos produtos sujeitos a alteração sem aviso prévio ou obrigações. As fotografias e/ou desenhos deste documento servem apenas para fins ilustrativos. Consulte o respectivo Manual de Instruções para instruções sobre o uso correto deste equipamento. A falta de atenção ao respectivo Manual do Operador no uso de nosso equipamento ou a operação da máquina em condições impróprias pode resultar em lesão grave ou morte. A única garantia aplicável aos nossos equipamentos é a garantia padrão por escrito, aplicável ao produto específico e à sua venda, sem que nenhuma outra, expressa ou implícita, seja oferecida pela Terex. Os produtos e serviços listados podem ser marcas comerciais, marcas de serviço ou nomes-fantasia da Terex Corporation e/ou suas subsidiárias nos EUA e em outros países. Todos os direitos reservados. Terex® é marca registrada da Terex Corporation nos EUA e muitos outros países.

Вступает в силу: февраль 2019.

Технические характеристики и цены могут изменяться без предварительного уведомления и без каких-либо обязательств для производителя. Фотографии и (или) чертежи, использованные в документе, приведены исключительно в качестве иллюстраций. Инструкции по правилам эксплуатации даются в соответствующих руководствах для операторов данного оборудования. Невыполнение рекомендаций руководства по эксплуатации нашего оборудования или другие безответственные действия могут повлечь серьезные травмы или смерть. Единственной гарантией, действующей в отношении нашего оборудования, является стандартная форма письменной гарантии на данный тип оборудования и на условия его продажи.

Terex Cranes 2019

Terex Cranes, Global Marketing, Europa Allee 2, 66482 Zweibrücken, Germany
Tel. +49 (0) 6332 830, Email: info.cranes@terex.com, www.terex.com/cranes



www.terex.com/cranes

Brochure Reference: TC-DS-M-E/F/G/I/S/P/R-CTT202-8-02/19



WORKS FOR YOU.™